

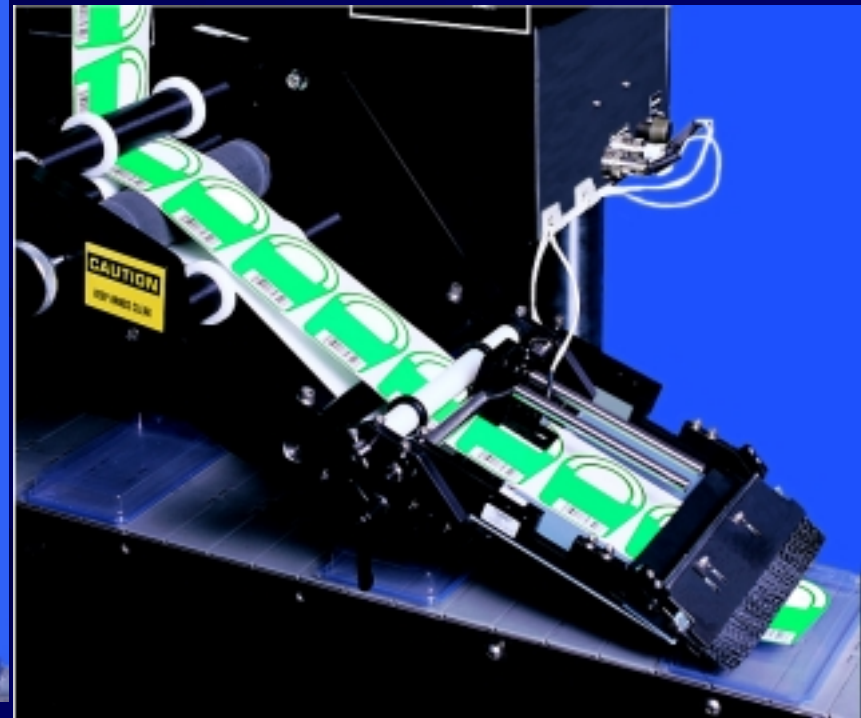

# MODEL 2115 WIPE ON



# MODEL 2115 WIPE ON SPECIFICATIONS

- The Model 2115 Wipe On labeler is a high speed stepper driven labeling machine designed for very accurate label placement.
- Standard dispense speeds to 1250" per minute with the option of attaining speeds up to 2000" per minute with label rolls of 20" in diameter.
- Reliable operation is ensured by utilizing a menu driven micro-processor which permits repeatable settings and constant monitoring.
- Adjustable label sensor allows for quick changeovers without sacrificing accuracy.
- The 2115's rugged corrosion resistant, stainless steel and anodized aluminum housing provides durability and maintenance-free operation even in hostile environments.

<b>Dimensions:</b>	Height: 20" (508 mm) Width: 29" (737 mm) Length: 31" (787 mm)
<b>Weight:</b>	120 lbs. (55 kgs)
<b>Label Dimensions:</b>	Label Width: 7" (178 mm) Label Length Dependent on Application.
<b>Label Packaging:</b>	12" (305 mm) O.D. Rolls Maximum on 3" (76 mm) I.D. Cores Up to 20" (508 mm) Rolls With Powered Unwind.
<b>Dispense Speed:</b>	Up to 1250" Of Web Per Minute (Standard) Up to 2000" Of Web Per Minute With Powered Unwind
<b>Label Placement Accuracy:</b>	Up to +/- 1/32" (0.8 mm)
<b>Electrical:</b>	115 Volts AC, 60 Hz, 5 Amps. 220 Volts AC, 50 Hz Optional
<b>Air (As Needed):</b>	2 cfm at 60 psi to 90 psi when imprinter is used.

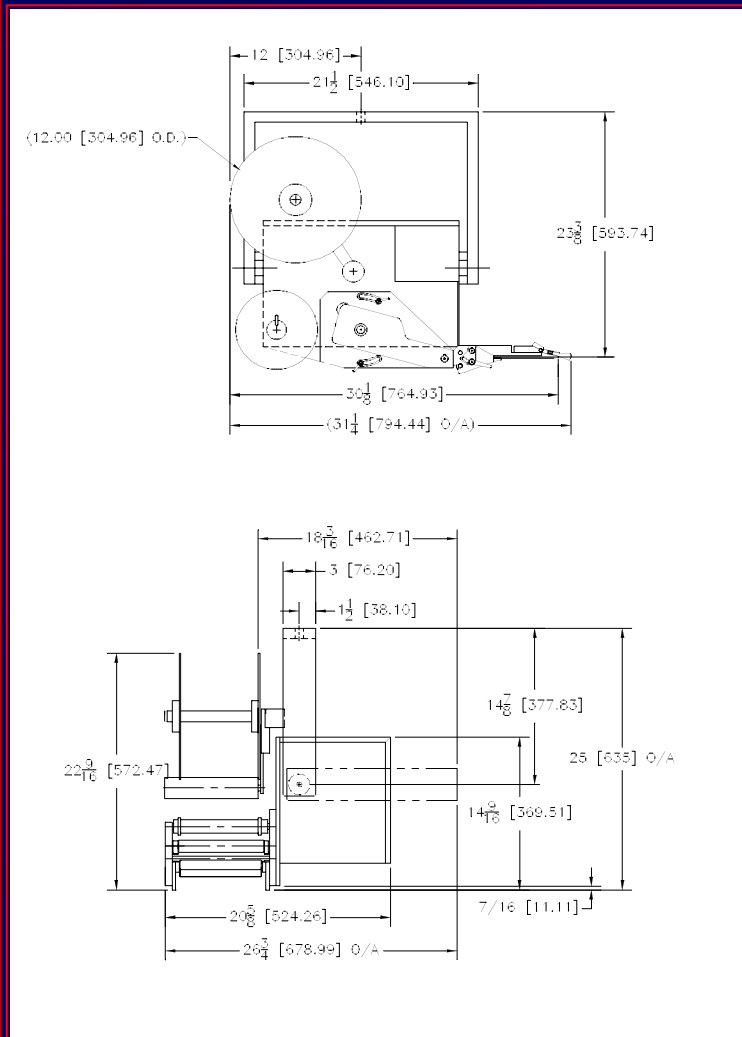

## Label-Aire, Incorporated

550 Burning Tree Road  
Fullerton, CA 92833

Phone (714) 441-0700

Fax (714) 526-0300

Please visit us on the web at [www.label-aire-inc.com](http://www.label-aire-inc.com)

## Label-Aire A/S

Industrivej 9  
DK-9510 Arden, Denmark

Phone 459 856 2900

Fax 459 856 2901

## Distributed by: